

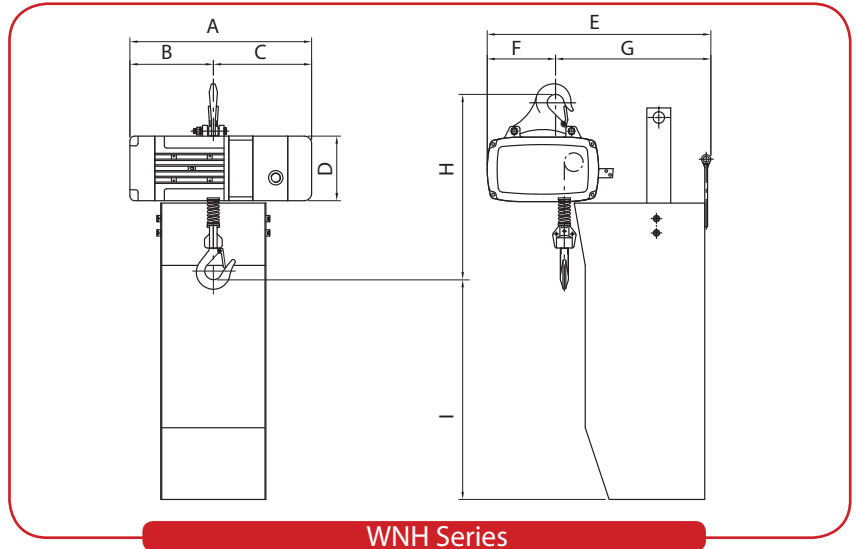

Tusker® Wind Turbine Hoist (WNH Series)

CHAIN HOISTS & TROLLEYS



WNH Series

- ※ The actual dimension of chain bucket is different from subject, the picture is only for reference.
- ※ Operates on single voltage between 220V~600V, 3ph ※ 48V control voltage for operator safety.

Model	S.W.L (kg)	Lift (m)	Dimensions (mm)									Load Chain	Hoisting				E.D Rating (%)	Load Chain Fall no.	N.W / G.W. (Kg)
			A	B	C	D	E	F	G	H	I		Speed (m/min)		Motor Power (Kw) (Pole)				
			50 Hz	60 Hz	50 Hz	60 Hz													
WNH-012	125	80	380	175	205	135	472	143	329	376	460	4.0 x12.0	20	20	0.6x2p	0.6x2p	40	1	58/60
WNH-025	250	80	468	221	247	156	534	186	353	485	701	6.3 x19.1	20	20	1.6x2p	1.6x2p	40	1	111/113
WNH-050	500	80	488	240	248	170	554	188	366	520	710	7.1 x20.2	20	20	2.5x2p	2.5x2p	40	1	145/148
WNH-100	1000	80	488	240	248	170	624	188	436	520	750	8.0 x24.0	10	10	2.5x2p	2.5x2p	40	1	145/148

- ※ Operates on single voltage between 220V~600V, 3ph ※ 48V control voltage for operator safety.

Features:

- High Speed Operation
- Quiet
- Reliable
- Solid Build Quality

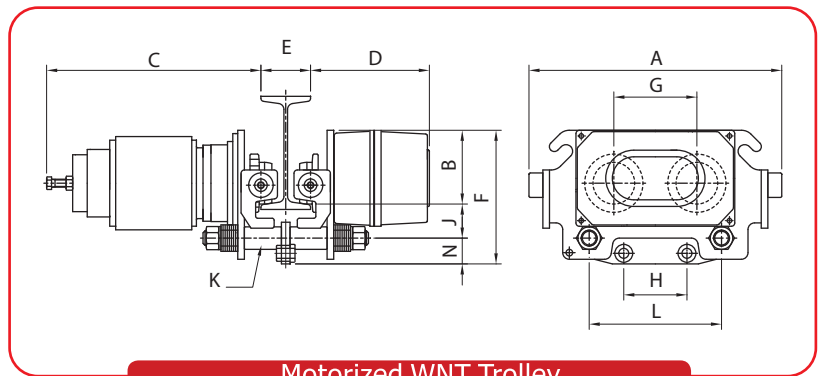

Motorized WNT Trolley

Model	Dimensions (mm)												Speed (m/min)		Motor Power (Kw) (Pole)	N.W (kg)	Min Radius of Curve (m)
	A	B	C	D	E	F	G	H	L	J	N	K	50 Hz	60 Hz			
	WNT-012	382	124.5	324	180	75-125	217	125.5	120	200	51.5	41	7/8"-9UNC (φ 22.2)	20	24		
WNT-025	382	124.5	324	180	75-125	217	125.5	120	200	51.5	41	7/8"-9UNC (φ 22.2)	20	24	0.12x2p	45	1.3
WNT-050	382	124.5	324	180	75-125	217	125.5	120	200	51.5	41	7/8"-9UNC (φ 22.2)	20	24	0.18x2p	45	1.3
WNT-100	382	124.5	324	180	75-125	217	125.5	120	200	51.5	41	7/8"-9UNC (φ 22.2)	20	24	0.18x2p	45	1.3

- ※ Different flange with options available on request. Maximum: 300mm